

## EFFECTIVE ELASTIC PROPERTIES OF MATERIALS WITH HIGH CONCENTRATION OF ALIGNED SPHEROIDAL PORES

M. HLAVÁČEK

Institute of Theoretical and Applied Mechanics, Czechoslovak Academy of Sciences,  
 Vyšehradská 49, 12849 Prague 2, Czechoslovakia

(Received 16 September 1984)

**Abstract**—A model of elastic transversely isotropic porous materials is presented. It may have applications with cancellous bone. The arrangement of aligned spheroidal pores is obtained through a homological transformation from Hashin's composite-sphere model. The volume fraction  $C$  of the matrix is assumed small. Two extremal variational principles of the theory of elasticity yield some inequalities or bounds for the derivatives with respect to  $C$  at  $C = 0$  of five macroscopic moduli. By using inhomogeneous stress boundary conditions for a hollow spheroidal element, the bounds are considerably improved. They coincide with the upper bounds for spherical pores. The bounds for the derivatives with respect to  $C$  at  $C = 0$  of five moduli, obtained from a kinematically admissible displacement, are of a simple form and can be used for an approximation to five macroscopic moduli for  $C \ll 1$ .

### 1. INTRODUCTION

Cancellous bone consists of a network of hard interconnected filaments called trabeculae interspersed with marrow. We could simply look upon a cancellous bone as an anisotropic composite material consisting of a relatively stiff viscoelastic bone matrix with pores of complicated shapes filled with a relatively weak viscous marrow.

To simplify, we neglect the stiffness of marrow and approximate the pores by aligned similar spheroids. The matrix material is considered isotropic and linearly elastic, and only the case of a high porosity ( $C \ll 1$ ) is dealt with in this paper.

For a special arrangement of elastic isotropic spherical inclusions in an elastic isotropic matrix called the composite-sphere model, Hashin[1] obtained the exact macroscopic bulk modulus  $\bar{\kappa}$  and bounds for the macroscopic shear modulus  $\bar{\mu}$  for any volume fraction  $c$  of inclusions. For spherical pores the bounds for  $\bar{\mu}$  were given in [2], eqns (3.25), (3.26), in the simple explicit form

$$\mu' \leq \bar{\mu} \leq \mu'',$$

$$\mu' = \left\{ 1 - \frac{[15(1 - \nu)/(7 - 5\nu)]c}{1 + c[2(4 - 5\nu)/(7 - 5\nu) - [126/(7 + 5\nu)(7 - 5\nu)]\phi(c)} \right\} \mu, \quad (1.1)$$

$$\mu'' = \left\{ 1 - \frac{15(1 - \nu)c}{7 - 5\nu + 2(4 - 5\nu)c} \right\} \mu, \quad \phi(c) = \frac{(1 - c^{2/3})^2}{1 - c^{7/3}}.$$

$\mu$  and  $\nu$  are the shear modulus and the Poisson ratio of the matrix. For  $c \ll 1$ ,  $\mu'$ ,  $\mu''$ ,  $\bar{\mu}$  can be written in the form

$$\mu'(c) = \mu'_0 + \mu'_1 c + O(c^2), \quad \mu''(c) = \mu''_0 + \mu''_1 c + O(c^2),$$

$$\bar{\mu}(c) = \bar{\mu} \Big|_{c=0} + \frac{d\bar{\mu}}{dc} \Big|_{c=0} c + O(c^2),$$

$$\mu'_0 = \mu''_0 = \mu, \quad \mu'_1 = \mu''_1 = -\frac{15(1 - \nu)}{7 - 5\nu} \mu.$$

For  $c \rightarrow 0$  we have from (1.1)<sub>1</sub>

$$\bar{\mu} |_{c=0} = \mu_0^l = \mu_0^u.$$

Subtracting  $\mu$  in (1.1)<sub>1</sub> and dividing by  $c$ , we get for  $c \rightarrow 0$

$$\frac{d\mu}{dc} \Big|_{c=0} = \mu_1^l = \mu_1^u.$$

Denoting by  $C$  the volume fraction of matrix, substituting  $c = 1 - C$  into (1.1) and expanding  $\mu^L(C) = \mu^l(c)$ ,  $\mu^U(C) = \mu^u(c)$  and  $\bar{\mu}(C)$  in powers of  $C$  for  $C \ll 1$ , we similarly get

$$\begin{aligned} \mu^L(C) &= \mu_0^l + \mu_1^l C + O(C^2), & \mu^U(C) &= \mu_0^u + \mu_1^u C + O(C^2), \\ \bar{\mu}(C) &= \bar{\mu} \Big|_{c=0} + \frac{d\bar{\mu}}{dC} \Big|_{c=0} C + O(C^2), & (1.2) \\ \mu_0^l &= \mu_0^u = 0, & \mu_1^l &= \frac{5(1+\nu)}{3(7+5\nu)} \mu, & \mu_1^u &= \frac{7-5\nu}{15(1-\nu)} \mu, \end{aligned}$$

which results in

$$\bar{\mu} |_{c=0} = 0, \quad \mu_1^l \leq \frac{d\bar{\mu}}{dC} \Big|_{c=0} \leq \mu_1^u. \quad (1.2)$$

For  $-1 \leq \nu \leq 1/2$  we have  $\mu_1^l < \mu_1^u$ , and the situation differs from the case  $c \ll 1$  (see Fig. 1). For fixed  $\mu, \nu$  the curves  $\mu^l(c), \mu^u(c)$  have the same tangent at  $c = 0$  but different tangents at  $c = 1$  ( $C = 0$ ). Thus, the bounds (1.1) for  $\bar{\mu}(c)$  yield the exact  $d\bar{\mu}/dc |_{c=0}$ , but only bounds for  $d\bar{\mu}/dC |_{C=0}$ .

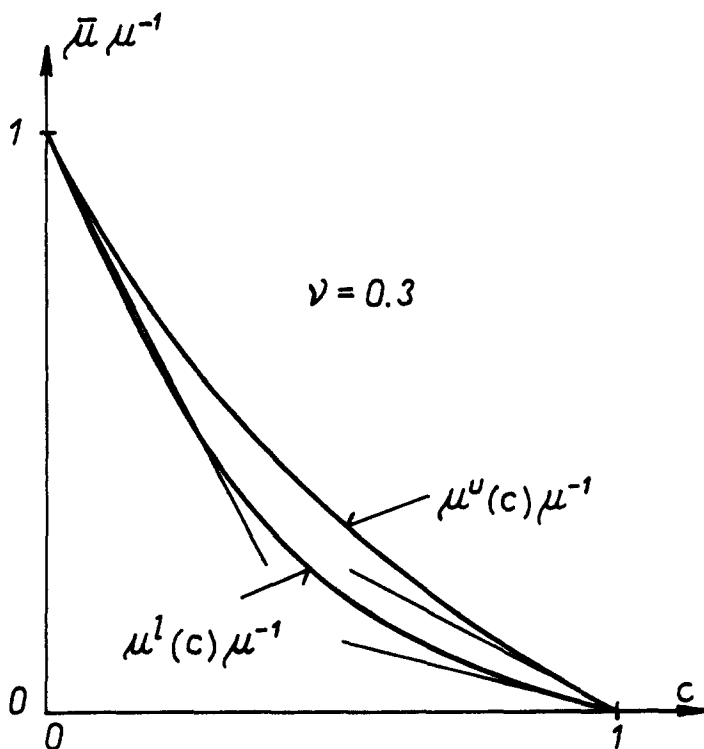

Fig. 1. Bounds (1.1) for  $\bar{\mu}$  from [2]. Spherical pores,  $\nu = 0.3$

In Section 2, a special arrangement of similar and aligned spheroidal pores is defined. It is obtained by a homological transformation from a hollow-sphere assemblage[1]. Kinematically and statically admissible fields of the displacement and the stress are chosen using homogeneous boundary conditions for the displacement and the stress vector[1] on the boundaries of hollow elements, respectively. These admissible fields also satisfy the condition of zero stress vector on the surfaces of pores. For a high concentration of pores ( $C = 1 - c \ll 1$ ) the energy of this kinematically admissible field to  $O(C)$  and that of this statically admissible field to  $O(C^{-1})$  are obtained in Sections 3 and 4. For the statically admissible field much prolate or oblate spheroidal pores must be excluded. The theorems of minimum potential energy and minimum complementary energy yield then some inequalities or bounds for the derivatives with respect to  $C$  at  $C = 0$  of five macroscopic moduli. In Section 6 by using certain microscopically inhomogeneous axially symmetric stress boundary conditions for the statically admissible field, the bounds for the derivatives of three moduli are improved considerably. In the case of spherical pores this improved lower bound for  $d\bar{\mu}/dC|_{C=0}$  coincides with the upper bound yielding for  $d\bar{\mu}/dC$  at  $C = 0$  the exact value given by  $\mu^V$  in (1.2).

## 2 MICROSCOPIC ARRANGEMENT OF PORES AND VARIATIONAL PRINCIPLES

Assume that a porous material can be divided into hollow elements  $\mathcal{E}$  shown in Fig. 2. At the centre of each element  $\mathcal{E}$  one spheroidal pore is situated. The outer and inner surface of each  $\mathcal{E}$  are aligned similar ellipsoids of revolution. All  $\mathcal{E}$  are similar, and their sizes can vary to infinitesimal values. The material is constructed by filling a body with such parallel-oriented elements firmly connected at the points of contact.

The existence of such an arrangement is given by that of the composite-sphere arrangement[1]. In fact, the former is obtained from the latter by setting a correspondence of points  $P \rightarrow P'$ ,  $P = (x_1^0, x_2^0, x_3^0)$ ,  $P' = (x_1^0, x_2^0, kx_3^0)$ , where  $k = \text{const.}$  and  $x_i^0$  are the Cartesian coordinates. For  $k \neq 1$  similar and aligned spheroids correspond to spheres, points of contact of neighbouring spheroids correspond to those of neighbouring spheres and the volume fraction of pores is preserved in all elements.

Let us have a body  $V$  with a boundary  $S$  containing a large number of elements  $\mathcal{E}$ . Two boundary-value problems in  $V$  are considered:

$$u_i^0 = E_{ij}^0 x_j^0 \quad \text{on } S, \quad (2.1)$$

$$t_i^0 = S_{ij}^0 n_j^0 \quad \text{on } S. \quad (2.2)$$

$u_i^0$ ,  $t_i^0$ ,  $n_i^0$  denote the displacement vector, the stress vector and the unit outward normal to  $S$ , respectively. In what follows, the upper index 0 denotes a Cartesian component.  $E_{ij}^0$ ,  $S_{ij}^0$  are given constant symmetric tensors. Then  $\bar{E}_{ij}^0$  and  $\bar{S}_{ij}^0$  are the volume average strain tensor  $\bar{\epsilon}_{ij}^0$  and the volume average stress tensor  $\bar{\sigma}_{ij}^0$  for the boundary-value problems (2.1) and (2.2), respectively. If for any sufficiently large subregion  $V'$  of  $V$ ,  $\bar{\epsilon}_{ij}^0$ ,  $\bar{\sigma}_{ij}^0$  for the problems (2.1), (2.2) are not changed, the material is called macroscopically homogeneous. The macroscopic moduli  $\bar{C}_{ijkl}^0$  and compliances  $\bar{D}_{ijkl}^0$  are then defined by

$$\bar{\sigma}_{ij}^0 = \bar{C}_{ijkl}^0 \bar{\epsilon}_{kl}^0, \quad \bar{\epsilon}_{ij}^0 = \bar{D}_{ijkl}^0 \bar{\sigma}_{kl}^0. \quad (2.3)$$

The elastic strain energy density  $W$  of the composite material (here we deal with a composite of a special type—a porous material) for problem (2.1) is

$$W = \frac{1}{2} \bar{C}_{ijkl}^0 E_{ij}^0 E_{kl}^0, \quad (2.4)$$

and for problem (2.2)

$$W = \frac{1}{2} \bar{D}_{ijkl}^0 S_{ij}^0 S_{kl}^0. \quad (2.5)$$

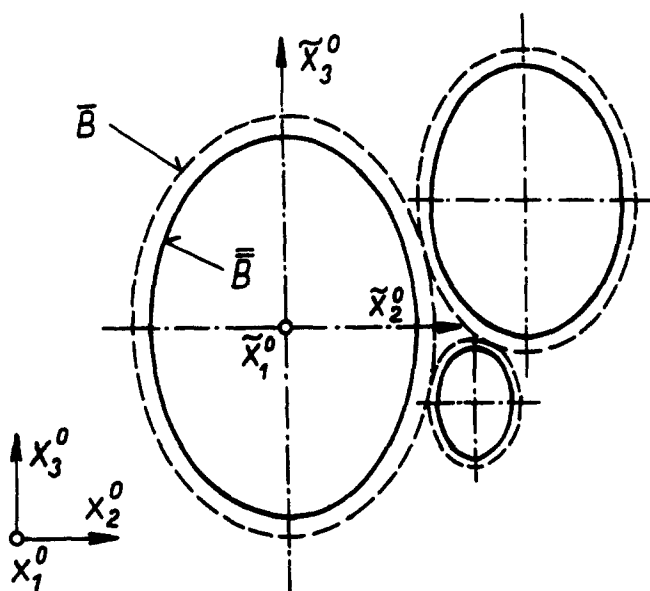

Fig 2 Microscopic geometry of pores

If the forms (2.4), (2.5) are positive-definite, the principle of minimum potential energy for problem (2.1) gives

$$W^{(u)} - W \geq 0, \quad (2.6)$$

where  $W^{(u)}$  denotes the strain energy density of the composite for a kinematically admissible displacement field. The principle of minimum complementary energy yields for problem (2.2) is

$$W^{(\sigma)} - W \geq 0, \quad (2.7)$$

with  $W^{(\sigma)}$  being the strain energy density of a statically admissible stress field.

Assume that the arrangement of aligned hollow elements  $\mathcal{E}$  is such that the porous material is macroscopically homogeneous and transversely isotropic with the  $x_1^0$ -axis as that of isotropy. We write Hooke's law (2.3)<sub>1</sub> in the form

$$\begin{aligned} \bar{\sigma}_{11}^0 &= \bar{C}_{11}^0 \bar{\epsilon}_{11}^0 + \bar{C}_{12}^0 \bar{\epsilon}_{22}^0 + \bar{C}_{13}^0 \bar{\epsilon}_{33}^0, & \bar{\sigma}_{13}^0 &= 2\bar{C}_{44}^0 \bar{\epsilon}_{13}^0, \\ \bar{\sigma}_{22}^0 &= \bar{C}_{12}^0 \bar{\epsilon}_{11}^0 + \bar{C}_{11}^0 \bar{\epsilon}_{22}^0 + \bar{C}_{13}^0 \bar{\epsilon}_{33}^0, & \bar{\sigma}_{23}^0 &= 2\bar{C}_{44}^0 \bar{\epsilon}_{23}^0, \\ \bar{\sigma}_{33}^0 &= \bar{C}_{13}^0 \bar{\epsilon}_{11}^0 + \bar{C}_{13}^0 \bar{\epsilon}_{22}^0 + \bar{C}_{33}^0 \bar{\epsilon}_{33}^0, & \bar{\sigma}_{12}^0 &= (\bar{C}_{11}^0 - \bar{C}_{12}^0) \bar{\epsilon}_{12}^0 \end{aligned} \quad (2.8)$$

with five independent macroscopic moduli

$$\{\bar{C}_{11}^0, \bar{C}_{12}^0, \bar{C}_{13}^0, \bar{C}_{33}^0, \bar{C}_{44}^0\} = \bar{\mathcal{C}}^0.$$

(2.4) takes the form

$$\begin{aligned} W &= \frac{1}{2} \bar{C}_{11}^0 (E_{11}^{02} + E_{22}^{02}) + \frac{1}{2} \bar{C}_{33}^0 E_{33}^{02} + \bar{C}_{12}^0 E_{11}^0 E_{22}^0 \\ &+ \bar{C}_{13}^0 (E_{11}^0 + E_{22}^0) E_{33}^0 + 2\bar{C}_{44}^0 (E_{13}^{02} + E_{23}^{02}) + (\bar{C}_{11}^0 - \bar{C}_{12}^0) E_{12}^{02}. \end{aligned} \quad (2.9a)$$

We introduce the following notation for the form of this type:

$$W = \mathcal{F}(E_{ij}^0, \bar{\mathcal{C}}^0). \quad (2.9b)$$

(2.9) is positive-definite if and only if

$$\begin{aligned} \bar{C}_{11}^0 + \bar{C}_{12}^0 > 0, \quad \bar{C}_{33}^0 > 0, \quad \bar{C}_{44}^0 > 0, \\ \bar{C}_{11}^0 - \bar{C}_{12}^0 > 0, \quad \bar{C}_{33}^0(\bar{C}_{11}^0 + \bar{C}_{12}^0) > 2\bar{C}_{13}^0{}^2. \end{aligned} \quad (2.10)$$

If (2.10) holds, (2.8) can be inverted into

$$\begin{aligned} \bar{\epsilon}_{11}^0 &= \bar{D}_{11}^0 \bar{\sigma}_{11}^0 + \bar{D}_{12}^0 \bar{\sigma}_{22}^0 + \bar{D}_{13}^0 \bar{\sigma}_{33}^0, & \bar{\epsilon}_{13}^0 &= 2\bar{D}_{44}^0 \bar{\sigma}_{13}^0, \\ \bar{\epsilon}_{22}^0 &= \bar{D}_{12}^0 \bar{\sigma}_{11}^0 + \bar{D}_{11}^0 \bar{\sigma}_{22}^0 + \bar{D}_{13}^0 \bar{\sigma}_{33}^0, & \bar{\epsilon}_{23}^0 &= 2\bar{D}_{44}^0 \bar{\sigma}_{23}^0, \\ \bar{\epsilon}_{33}^0 &= \bar{D}_{13}^0 \bar{\sigma}_{11}^0 + \bar{D}_{13}^0 \bar{\sigma}_{22}^0 + \bar{D}_{33}^0 \bar{\sigma}_{33}^0, & \bar{\epsilon}_{12}^0 &= (\bar{D}_{11}^0 - \bar{D}_{12}^0) \bar{\sigma}_{12}^0. \end{aligned} \quad (2.11)$$

where for the five macroscopic compliances

$$\{\bar{D}_{11}^0, \bar{D}_{12}^0, \bar{D}_{13}^0, \bar{D}_{33}^0, \bar{D}_{44}^0\} = \bar{\mathcal{D}}^0$$

we get

$$\begin{aligned} \bar{D}_{11}^0 + \bar{D}_{12}^0 &= \frac{1}{F_C} \bar{C}_{33}^0, \\ \bar{D}_{11}^0 - \bar{D}_{12}^0 &= \frac{1}{\bar{C}_{11}^0 - \bar{C}_{12}^0}, \\ \bar{D}_{33}^0 &= \frac{1}{F_C} (\bar{C}_{11}^0 + \bar{C}_{12}^0), \\ \bar{D}_{13}^0 &= -\frac{1}{F_C} \bar{C}_{13}^0, \\ \bar{D}_{44}^0 &= \frac{1}{4\bar{C}_{44}^0}, \\ F_C &= \bar{C}_{33}^0(\bar{C}_{11}^0 + \bar{C}_{12}^0) - 2\bar{C}_{13}^0{}^2. \end{aligned} \quad (2.12)$$

The inverse relations are

$$\begin{aligned} \bar{C}_{11}^0 + \bar{C}_{12}^0 &= \frac{1}{F_D} \bar{D}_{33}^0, \quad \bar{C}_{33}^0 = \frac{1}{F_D} (\bar{D}_{11}^0 + \bar{D}_{12}^0), \\ \bar{C}_{13}^0 &= -\frac{1}{F_D} \bar{D}_{13}^0, \quad F_D = \bar{D}_{33}^0(\bar{D}_{11}^0 + \bar{D}_{12}^0) - 2\bar{D}_{13}^0{}^2 = \frac{1}{F_C}. \end{aligned} \quad (2.13)$$

(2.5) has the form

$$W = \mathcal{F}(S_i^0, \bar{\mathcal{D}}^0). \quad (2.14)$$

### 3. STRAIN ENERGY DENSITY OF A KINEMATICALLY ADMISSIBLE FIELD

Consider an arbitrary hollow spheroidal element  $\mathcal{E}$ . At its centre  $\bar{x}_i^0$  introduce a local Cartesian coordinate system  $\bar{x}_i^0$  with the  $\bar{x}_1^0$ -axis lying in its axis of symmetry (Fig. 2):

$$\bar{x}_i^0 = x_i^0 - \bar{x}_i^0.$$

The length of the semiaxis of symmetry of the pore is denoted by  $\bar{c}$ , that of its transverse

semiaxis by  $\bar{a}$ .  $\alpha$  defined by

$$\alpha = \bar{a}/\bar{c} \quad (3.1)$$

defines the shape of the pore and is constant for all  $\mathcal{E}$ . The spheroidal coordinates  $r$ ,  $\vartheta$ ,  $\varphi$  are defined by

$$\bar{x}_1^0 = \bar{a}r \cos \varphi \sin \vartheta, \quad \bar{x}_2^0 = \bar{a}r \sin \varphi \sin \vartheta, \quad \bar{x}_3^0 = \bar{c}r \cos \vartheta. \quad (3.2)$$

We introduce the notation

$$\xi^1 = r, \quad \xi^2 = \vartheta, \quad \xi^3 = \varphi. \quad (3.3)$$

In what follows, the tensor components not having the upper index 0 are referred to the local curvilinear coordinates  $\xi^i$ . For the surface  $\bar{B}$  of the pore it is  $\xi^1 = 1$ , for the outer surface  $\bar{B}$  of  $\mathcal{E}$  it is  $\xi^1 = 1 + d$ ,  $d = \text{const}$ . In this paper we assume a small volume fraction  $C$  of the matrix, i.e.

$$C \ll 1. \quad (3.4)$$

We easily find

$$d = \frac{1}{3}C + O(C^2). \quad (3.5)$$

We follow Hashin[1] in choosing a kinematically admissible displacement. Let the displacement vector on  $\bar{B}$  of all  $\mathcal{E}$  be given by (2.1). Such a displacement would be there if the material were homogeneous. (2.1) yields  $\epsilon_{\alpha\beta}$  ( $\alpha, \beta = 2, 3$ ) on  $\bar{B}$  in the form

$$\epsilon_{\alpha\beta} = E_{ij}^0 \frac{\partial \bar{x}_i^0}{\partial \xi^\alpha} \frac{\partial \bar{x}_j^0}{\partial \xi^\beta}. \quad (3.6)$$

On the surfaces of the pores the stress vector equals zero, i.e.

$$\sigma^{1j} = 0 \quad \text{or} \quad \sigma_j^1 = \sigma^{1k} g_{kj} = 0 \quad \text{on} \quad \bar{B}, \quad (3.7)$$

where  $g_{ij}$  is the metric tensor

$$g_{ij} = \frac{\partial \bar{x}_k^0}{\partial \xi^i} \frac{\partial \bar{x}_k^0}{\partial \xi^j}. \quad (3.8)$$

(2.1) and (3.7) formulate a boundary-value problem for any  $\mathcal{E}$  cut off the material. As all  $\mathcal{E}$  are similar, aligned and (2.1) homogeneous, the stress and strain tensors in the corresponding points of all  $\mathcal{E}$  are the same. The displacement obtained by solving this problem for a single  $\mathcal{E}$  yields a kinematically admissible field in the whole body  $V$ .  $W^{(m)}$  is obtained by

$$W^{(m)} = W_{\mathcal{E}}^{(m)}/V_{\mathcal{E}}, \quad (3.9)$$

where  $W_{\mathcal{E}}^{(m)}$  and  $V_{\mathcal{E}}$  are the strain energy and the volume of any  $\mathcal{E}$ , respectively.  $W^{(m)}$  must be of the same form as  $W$  in (2.9a,b), i.e.

$$W^{(m)} = \mathcal{F}(E_{ij}^0, \mathcal{C}^0), \quad \mathcal{C}^0 = \{C_{11}^0, C_{12}^0, C_{13}^0, C_{33}^0, C_{44}^0\}. \quad (3.10)$$

The strain energy  $W_{\mathcal{E}}$  of  $\mathcal{E}$  is

$$W_{\mathcal{E}} = \iiint w \sqrt{g} \, d\xi^1 \, d\xi^2 \, d\xi^3, \quad w = \frac{1}{2} \sigma'^i \epsilon_{ij}, \quad g = \det g_{ij}. \quad (3.11)$$

The integral in (3.11) is taken over the matrix jacket of  $\mathcal{E}$ . Hooke's law for an isotropic matrix is

$$\sigma'_j = 2\mu \left( \frac{\nu}{1-2\nu} \delta'_j \epsilon'_k + \epsilon'_j \right), \quad (3.12)$$

where  $\delta'_j$  is the Kronecker delta.

We shall find  $W^{(u)}$  or the coefficients  $\mathcal{C}^0$  to  $O(C)$  or  $O(d)$ . Let us choose fixed  $\xi^2, \xi^3$  and consider a point  $\xi = (1, \xi^2, \xi^3)$  on  $\bar{B}$  and the corresponding point  $\bar{\xi} = (1 + d, \xi^2, \xi^3)$  on  $\bar{B}$  in a chosen  $\mathcal{E}$ . Using the Taylor expansion of  $\sigma'_j$  at  $\bar{\xi}$  and (3.7), we have

$$\sigma'_j |_{\bar{\xi}} = O(d). \quad (3.13)$$

Inserting (3.13) into (3.12) written at  $\xi$  for  $i = 1$ , we get three linear equations for  $\epsilon_{11}, \epsilon_{12}, \epsilon_{13}$ . The solution is

$$\begin{aligned} (1-\nu)g^{11}\epsilon_{11} &= \frac{1}{g^{11}} (\epsilon_{22}g^{12}g^{12} + 2\epsilon_{23}g^{12}g^{13} + \epsilon_{33}g^{13}g^{13}) \\ &\quad - \nu(\epsilon_{22}g^{22} + 2\epsilon_{23}g^{23} + \epsilon_{33}g^{33}) + O(d), \\ g^{11}\epsilon_{12} &= -\epsilon_{22}g^{12} - \epsilon_{23}g^{13} + O(d), \\ g^{11}\epsilon_{13} &= -\epsilon_{23}g^{12} - \epsilon_{33}g^{13} + O(d), \quad g^{ij} = \frac{\partial \xi^i}{\partial \bar{x}^0_\lambda} \frac{\partial \xi^j}{\partial \bar{x}^0_\lambda}. \end{aligned} \quad (3.14)$$

All functions in (3.14) are taken at  $\bar{\xi}$ . Substituting again (3.14) into (3.12), we get  $\sigma^{\alpha\beta}$  for  $\alpha, \beta = 2, 3$  at  $\bar{\xi}$  to  $O(1)$ . Then  $w^{(u)}$  at  $\bar{\xi}$  of this kinematically admissible field can be obtained in the form

$$\begin{aligned} w^{(u)} &= \frac{\mu}{1-\nu} \frac{G^2}{g^{11}g^{11}} (\epsilon_{22}g_{33} - 2\epsilon_{23}g_{23} + \epsilon_{33}g_{22})^2 \\ &\quad + 2\mu \frac{G}{g^{11}} (\epsilon_{23}^2 - \epsilon_{22}\epsilon_{33}) + O(d), \quad G = \det g^{ij} = \frac{1}{g}. \end{aligned} \quad (3.15)$$

To calculate  $W_{\mathcal{E}}^{(u)}$  to  $O(d)$ , we shall use (3.2), (3.3), (3.8), (3.14)<sub>4</sub>, (3.15), (3.11), (3.6), (3.9) and

$$\int_{\bar{\xi}^1}^{\bar{\xi}^1} w \sqrt{g} \, d\xi^1 = (w \sqrt{g}) |_{\bar{\xi}} d + O(d^2). \quad (3.16)$$

By writing in (3.10)

$$\mathcal{C}^0 = \mathcal{C}^{10}C + O(C^2), \quad \mathcal{C}^{10} = \{C_{11}^{10}, C_{12}^{10}, C_{13}^{10}, C_{33}^{10}, C_{44}^{10}\}, \quad (3.17)$$

it is

$$W^{(u)} = \mathcal{F}(E_{ij}^0, \mathcal{C}^{10})C + O(C^2). \quad (3.18)$$

$\mathcal{C}^{10}$  are calculated by considering three deformation states:

- ( $\alpha$ )  $E_{11}^0 = E_{22}^0 \neq 0, E_{33}^0 \neq 0$ , all other  $E_{ij}^0 = 0$ ,
- ( $\beta$ )  $E_{23}^0 = E_{32}^0 \neq 0$ , all other  $E_{ij}^0 = 0$ ,
- ( $\gamma$ )  $E_{12}^0 = E_{21}^0 \neq 0$ , all other  $E_{ij}^0 = 0$ .

Using (3.2), (3.3), (3.8), (3.14)<sub>4</sub>, (3.6), (3.15) and (3.5), we get  $w^{(a)}$  at  $\bar{\xi} \in \bar{B}$  of these deformation states in the form

$$\begin{aligned} w_{(\alpha)}^{(a)} &= \frac{\mu}{1-\nu} \left[ \frac{1}{T} (\alpha^2 E_{11}^0 \cos^2 \vartheta + E_{33}^0 \sin^2 \vartheta) + E_{11}^0 \right]^2 \\ &\quad - \frac{2\mu}{T} (\alpha^2 E_{11}^0 \cos^2 \vartheta + E_{11}^0 E_{33}^0 \sin^2 \vartheta), \quad T = \sin^2 \vartheta + \alpha^2 \cos^2 \vartheta, \\ w_{(\beta)}^{(a)} &= \frac{\mu E_{23}^0}{T} \left[ \frac{\alpha^2}{(1-\nu)T} \sin^2 \varphi \sin^2 \vartheta \cos^2 \vartheta + 2 \cos^2 \varphi \sin^2 \vartheta \right], \\ w_{(\gamma)}^{(a)} &= \frac{\mu E_{12}^0}{T} \left[ \frac{4}{(1-\nu)T} \sin^2 \varphi \cos^2 \varphi \sin^4 \vartheta + 2\alpha^2 \cos^2 \vartheta \right]. \end{aligned} \quad (3.19)$$

Through (3.11), (3.16), (3.19), (3.9), (3.17), (3.18), (2.9a,b) we have for  $\alpha \neq 1$

$$\begin{aligned} C_{11}^{10} + C_{12}^{10} &= \frac{\mu}{\alpha^2 - 1} \left\{ \frac{3\alpha^2(2\alpha^2 - 1) + 2(\alpha^2 - 1)^2 - \alpha^2(7\alpha^2 - 4)Z}{2(1-\nu)(\alpha^2 - 1)} \right. \\ &\quad \left. + 2\alpha^2(Z - 1) \right\}, \\ C_{11}^{10} - C_{12}^{10} &= \frac{\mu}{\alpha^2 - 1} \left\{ \frac{\alpha^2 + 2 + \alpha^2(\alpha^2 - 4)Z}{4(1-\nu)(\alpha^2 - 1)} + 2\alpha^2(1 - Z) \right\}, \\ C_{13}^{10} &= \frac{\mu}{\alpha^2 - 1} \left\{ \frac{3\alpha^4 Z - (5\alpha^2 - 2)}{2(1-\nu)(\alpha^2 - 1)} + 1 - \alpha^2 Z \right\}, \\ C_{33}^{10} &= \frac{\mu}{(1-\nu)(\alpha^2 - 1)^2} \{ \alpha^2 + 2 + \alpha^2(\alpha^2 - 4)Z \}, \\ C_{44}^{10} &= \frac{\mu}{2(\alpha^2 - 1)} \left\{ \frac{\alpha^2[(\alpha^2 + 2)Z - 3]}{(1-\nu)(\alpha^2 - 1)} + \alpha^2 Z - 1 \right\}, \end{aligned} \quad (3.20)$$

where

$$Z = \frac{1}{\sqrt{\alpha^2 - 1}} \arctan \sqrt{\alpha^2 - 1} \quad \text{for } \alpha > 1, \quad (3.21)$$

$$Z = \frac{1}{\sqrt{1 - \alpha^2}} \ln \frac{1 + \sqrt{1 - \alpha^2}}{\alpha} \quad \text{for } \alpha < 1. \quad (3.22)$$

$\alpha$  is a shape parameter of pores defined in (3.1). The case (3.21) corresponds to the pores in the shape of flattened spheroids, (3.22) to those of elongated ones. In deducing (3.20), we assumed  $\alpha \neq 1$ .  $\alpha = 1$  refers to the spherical pores. By taking the limit  $\alpha \rightarrow 1^+$  in (3.20), (3.21) and  $\alpha \rightarrow 1^-$  in (3.20), (3.22), we get the upper bound (1.2) for  $d\bar{\mu}/dC$  at  $C = 0$  and the exact  $d\bar{\mu}/dC$  at  $C = 0$  consistently with [1].

#### 4 STRAIN ENERGY DENSITY OF A STATICALLY ADMISSIBLE FIELD

In this section we follow Hashin[1] in choosing a statically admissible stress field. Set the stress vector  $t_i^0$  on  $\bar{B}$  of all  $\mathcal{E}$  be given by (2.2). It is

$$\sigma^{i'} = S_{\lambda i'}^0 \frac{\partial \xi^1}{\partial \bar{x}_\lambda^0} \frac{\partial \xi^j}{\partial \bar{x}_j^0} \quad \text{on } \bar{B}. \quad (4.1)$$

These stress components would be there in the case of a homogeneous material. On



the surface of the pores condition (3.7) is satisfied. Again, a boundary-value problem is defined for any  $\mathcal{E}$  cut off the material and the stress field obtained by solving this problem for one  $\mathcal{E}$  yields a statically admissible field in the porous material.

(3.12) can be solved for  $\epsilon'_i$  to give  $w$  defined in (3.11)<sub>2</sub> the form

$$w = \frac{1}{2\mu} \left( \sigma'_i \sigma'_i - \frac{\nu}{1+\nu} \sigma'_k \sigma'_k \right). \quad (4.2)$$

To calculate the strain energy  $W^{(\sigma)}$  of  $\mathcal{E}$  to  $O(d^{-1})$ , we see from (3.16) that  $w$  must be found to  $O(d^{-2})$ , and from (4.2) that  $\sigma'_i$  must be known to  $O(d^{-1})$ . If the distance of any two corresponding points  $\bar{\xi}$ ,  $\bar{\xi}$  is small in comparison with the dimensions of  $\mathcal{E}$  and with the main radii of curvature of  $\bar{B}$  at  $\bar{\xi}$  and  $\bar{B}$  at  $\bar{\xi}$  the classical theory of thin shells yields the result that  $W^{(\sigma)}$  is given to  $O(d^{-1})$  by the work of the membrane forces only. The above-mentioned conditions are not satisfied for much prolate or much oblate spheroidal elements. For the curvilinear coordinates  $\xi^i$  this work is done by the components  $\sigma^{22}$ ,  $\sigma^{23}$ ,  $\sigma^{33}$  taken constant for  $\xi^i \in (1, 1+d)$ . They can be found from the equations of equilibrium

$$\sigma_{,j}{}^{i'} + \sigma^{i'j} \Gamma'_{kj} + \sigma^{i'k} \Gamma'_{kj} = 0, \quad \Gamma'_{ij} = \frac{1}{2} g^{kl} (g_{il,j} + g_{jl,i} - g_{ij,l}). \quad (4.3)$$

Here a comma followed by an index denotes partial differentiation with respect to the corresponding  $\xi^i$ . Using (3.7), we write to  $O(d^{-1})$

$$\sigma_{,i'}{}^{i'} |_{\bar{\xi}} = d^{-1} \sigma^{i'j} |_{\bar{\xi}}. \quad (4.4)$$

Introducing (3.7), (4.4) into (4.3) written at a point  $\bar{\xi} \in \bar{B}$ , we get three differential equations in  $\xi^2$ ,  $\xi^3$  for  $\sigma^{22}$ ,  $\sigma^{23}$ ,  $\sigma^{33}$ . As  $\mathcal{E}$  is closed, we have no boundary conditions for this system, but we can use the condition that the physical components  $\hat{\sigma}^{22}$ ,  $\hat{\sigma}^{23}$ ,  $\hat{\sigma}^{32}$ ,  $\hat{\sigma}^{33}$  must be bounded.  $\sigma^{22}$ ,  $\sigma^{23}$ ,  $\sigma^{33}$  obtained in this way give us through (4.2), (3.11), (3.16), (3.9)  $W^{(\sigma)}$  to  $O(d^{-1})$ . In contrast to the kinematically admissible field introduced in Section 3, however, this accuracy for  $W^{(\sigma)}$  is not guaranteed for very prolate or oblate spheroidal pores.  $W^{(\sigma)}$  is a quadratic form in  $S_{ij}^0$  of the same type as  $W$  given in (2.14), i.e.

$$W^{(\sigma)} = \mathcal{F}(S_{ij}^0, \mathcal{D}^0), \quad \mathcal{D}^0 = \{D_{11}^0, D_{12}^0, D_{13}^0, D_{33}^0, D_{44}^0\}. \quad (4.5)$$

Define  $\mathcal{D}^{10}$  by

$$C\mathcal{D}^0 = \mathcal{D}^{10} + O(C), \quad \mathcal{D}^{10} = \{D_{11}^{10}, D_{12}^{10}, D_{13}^{10}, D_{33}^{10}, D_{44}^{10}\}. \quad (4.6)$$

Then

$$CW^{(\sigma)} = \mathcal{F}(S_{ij}^0, \mathcal{D}^{10}) + O(C). \quad (4.7)$$

$\mathcal{D}^{10}$  are calculated by using these three stress states:

( $\alpha$ )  $S_{11}^0 = S_{22}^0 \neq 0$ ,  $S_{33}^0 \neq 0$ , all other  $S_{ij}^0 = 0$ ,

( $\beta$ )  $S_{13}^0 = S_{31}^0 \neq 0$ , all other  $S_{ij}^0 = 0$ ,

( $\gamma$ )  $S_{12}^0 = S_{21}^0 \neq 0$ , all other  $S_{ij}^0 = 0$ .

The nonzero Christoffel symbols  $\Gamma'_{ij}$  defined in (4.3)<sub>2</sub> are obtained through (3.2), (3.3), (3.8), (3.14)<sub>4</sub> as

$$\Gamma_{12}^2 = \Gamma_{21}^2 = \Gamma_{13}^3 = \Gamma_{31}^3 = 1/r, \quad \Gamma_{22}^1 = -r, \quad \Gamma_{33}^1 = -r \sin^2 \vartheta, \\ \Gamma_{33}^2 = -\sin \vartheta \cos \vartheta, \quad \Gamma_{23}^3 = \Gamma_{32}^3 = (\cos \vartheta)/(\sin \vartheta). \quad (4.8)$$

Substitute (4.8), (3.7), (4.4) into (4.3)<sub>1</sub> written at a point  $\bar{\xi} \in \bar{B}$ . After excluding  $\sigma^{33}$ ,

we get (4.3)<sub>1</sub> in the form

$$\begin{aligned}\sigma_{,2}^{22} + \sigma_{,3}^{23} + \frac{2 \cos \vartheta}{\sin \vartheta} \sigma^{22} &= d^{-1} \left( \frac{\cos \vartheta}{\sin \vartheta} \sigma^{11} - \sigma^{12} \right) \Big|_{\bar{\xi}}, \\ \sigma_{,2}^{23} - \frac{1}{\sin^2 \vartheta} \sigma_{,3}^{32} + \frac{3 \cos \vartheta}{\sin \vartheta} \sigma^{23} &= -d^{-1} \left( \sigma^{13} + \frac{1}{\sin^2 \vartheta} \sigma_{,3}^{11} \right) \Big|_{\bar{\xi}}, \\ \sigma^{33} &= \frac{1}{\sin^2 \vartheta} (d^{-1} \sigma^{11} - \sigma^{22}) \Big|_{\bar{\xi}}.\end{aligned}\quad (4.9)$$

First, we find  $\sigma^{22}$ ,  $\sigma^{23}$ ,  $\sigma^{33}$  for the stress states ( $\alpha$ )–( $\gamma$ ).

( $\alpha$ ): Through (4.1), (3.2), (3.3)  $\sigma^{ij}$  at  $\bar{\xi} \in \bar{B}$  are

$$\begin{aligned}\sigma^{11} &= \frac{S_{11}^0}{\bar{a}^2} \sin^2 \vartheta + \frac{S_{33}^0}{\bar{c}^2} \cos^2 \vartheta, \\ \sigma^{12} &= \left( \frac{S_{11}^0}{\bar{a}^2} - \frac{S_{33}^0}{\bar{c}^2} \right) \frac{\sin \vartheta \cos \vartheta}{1+d}, \quad \sigma^{13} = 0.\end{aligned}\quad (4.10)$$

From axial symmetry it follows that

$$\sigma^{23} = \sigma_{,3}^{11} = \sigma_{,3}^{22} = 0.$$

By substituting (4.10) into (4.9), we get the following equation for  $\sigma^{22}$ :

$$\sigma_{,2}^{22} + \frac{2 \cos \vartheta}{\sin \vartheta} \sigma^{22} = \frac{S_{33}^0 \cos \vartheta}{\bar{c}^2 d \sin \vartheta}.$$

The general solution is

$$\sigma^{22} = \frac{m}{\sin^2 \vartheta} + \frac{S_{33}^0}{2\bar{c}^2 d},$$

where  $m$  is a constant. The physical component  $\hat{\sigma}^{22}$  is for  $r = 1$

$$\hat{\sigma}^{22} = \sigma^{22} \left( \frac{g_{22}}{g^{22}} \right)^{1/2} = \bar{a} \bar{c} \sigma^{22} \left( \frac{\bar{a}^2 \cos^2 \vartheta + \bar{c}^2 \sin^2 \vartheta}{\bar{a}^2 \sin^2 \vartheta + \bar{c}^2 \cos^2 \vartheta} \right)^{1/2}.$$

If  $\hat{\sigma}^{22}$  is bounded, then  $\sigma^{22}$  is also bounded, which yields  $m = 0$ . From (4.9)<sub>3</sub> we get to  $O(d^{-1})$

$$\sigma^{22} = \frac{S_{33}^0}{2\bar{c}^2 d}, \quad \sigma^{33} = \frac{1}{2d} \left[ \frac{2S_{11}^0}{\bar{a}^2} + \frac{S_{33}^0}{\bar{c}^2} \left( \frac{\cos^2 \vartheta}{\sin^2 \vartheta} - 1 \right) \right], \quad \sigma^{23} = 0. \quad (4.11)$$

( $\beta$ ): Through (4.1), (3.2), (3.3) we get  $\sigma^{ij}$  at  $\bar{\xi} \in \bar{B}$ :

$$\begin{aligned}\sigma^{11} &= \frac{2S_{13}^0}{\bar{a}\bar{c}} \cos \varphi \sin \vartheta \cos \vartheta, \quad \sigma^{12} = \frac{S_{13}^0 \cos \varphi}{\bar{a}\bar{c}(1+d)} (\cos^2 \vartheta - \sin^2 \vartheta), \\ \sigma^{13} &= -\frac{S_{13}^0 \sin \varphi \cos \vartheta}{\bar{a}\bar{c}(1+d) \sin \vartheta}.\end{aligned}\quad (4.12)$$

By substituting (4.12) into (4.9), we see that the shape of pores enters the system (4.9)

through the coefficient  $1/\bar{a}\bar{c}$  on the right-hand sides of (4.9) only. Therefore, except for this coefficient the solution of (4.9) is the same as that for a thin spherical shell. In [3] a solution to the equations of equilibrium for constant thickness membranes of revolution for a wind-type loading is given. (4.12) is of that type. Hence, we seek  $\sigma^{22}$ ,  $\sigma^{23}$ ,  $\sigma^{33}$  in the form

$$\sigma^{22} = 0, \quad \sigma^{23} = K \sin \varphi, \quad \sigma^{33} = \bar{\sigma}^{33}(\vartheta) \cos \varphi, \quad (4.13)$$

with  $K$  being a constant. By substituting (4.12), (4.13) into (4.9), we get to  $O(d^{-1})$

$$\sigma^{22} = 0, \quad \sigma^{23} = \frac{S_{13}^0 \sin \varphi}{\bar{a}\bar{c}d}, \quad \sigma^{33} = \frac{2S_{13}^0 \cos \varphi \cos \vartheta}{\bar{a}\bar{c}d \sin \vartheta}, \quad (4.14)$$

( $\gamma$ ): Through (4.1), (3.2), (3.3) we get at  $\bar{\xi} \in \bar{B}$

$$\begin{aligned} \sigma^{11} &= \frac{2S_{12}^0}{\bar{a}^2} \sin \varphi \cos \varphi \sin^2 \vartheta, \quad \sigma^{13} = \frac{S_{12}^0}{\bar{a}^2(1+d)} (\cos^2 \varphi - \sin^2 \varphi), \\ \sigma^{12} &= \frac{2S_{12}^0}{\bar{a}^2(1+d)} \sin \varphi \cos \varphi \sin \vartheta \cos \vartheta. \end{aligned} \quad (4.15)$$

Substitute (4.15) into (4.9) and again make use of a solution for a spherical membrane of radius  $\bar{a}$  and thickness  $\bar{a}d$ . Introduce new coordinate systems  $\bar{x}_i^0$ ,  $\xi''$  or  $r'$ ,  $\vartheta'$ ,  $\varphi'$

$$\begin{aligned} \bar{x}_1^0 &= \bar{x}_1^0, \quad \bar{x}_2^0 = \bar{x}_3^0, \quad \bar{x}_3^0 = -\bar{x}_2^0, \\ \xi'^1 &= r' = r, \quad \xi'^2 = \vartheta', \quad \xi'^3 = \varphi', \\ \bar{x}_1^0 &= \bar{a}r \cos \varphi' \sin \vartheta', \quad \bar{x}_2^0 = \bar{a}r \sin \varphi' \sin \vartheta', \quad \bar{x}_3^0 = \bar{a}r \cos \varphi'. \end{aligned}$$

The shear stress in the  $\bar{x}_1^0\bar{x}_2^0$ -plane of the  $\bar{x}_i^0$  system corresponds to that in the  $\bar{x}_1^0\bar{x}_3^0$ -plane of the  $\bar{x}_i^0$  system. Analogously to (4.14), for  $\bar{a} = \bar{c}$ , we have

$$\sigma'^{22} = 0, \quad \sigma'^{23} = \frac{S_{13}^0 \sin \varphi'}{\bar{a}^2 d}, \quad \sigma'^{33} = \frac{2S_{13}^0 \cos \varphi' \cos \vartheta'}{\bar{a}^2 d \sin \vartheta'}. \quad (4.16)$$

$\sigma''^{\nu\mu}$  are taken in the  $\xi''$  system,  $S_{ij}^0$  in the  $\bar{x}_i^0$  system, i.e.  $S_{13}^0 = S_{12}^0$ .  $\sigma^{22}$ ,  $\sigma^{23}$ ,  $\sigma^{33}$  in the  $\xi'$  system are

$$\sigma''^{\nu\mu} = \sigma'^{kl} \frac{\partial \xi^k}{\partial \xi'^l} \frac{\partial \xi^l}{\partial \xi''^m}, \quad \frac{\partial \xi^k}{\partial \xi'^l} = \frac{\partial \xi^k}{\partial \bar{x}_i^0} \frac{\partial \bar{x}_i^0}{\partial \xi'^l}. \quad (4.17)$$

By using  $\bar{a} = \bar{c}$ , (4.16) and (4.17), we get to  $O(d^{-1})$

$$\begin{aligned} \sigma^{22} &= \frac{2S_{12}^0}{\bar{a}^2 d} \sin \varphi \cos \varphi, \quad \sigma^{23} = \frac{S_{12}^0 \cos \vartheta}{\bar{a}^2 d \sin \vartheta} (\cos^2 \varphi - \sin^2 \varphi), \\ \sigma^{33} &= -\frac{2S_{12}^0 \cos^2 \vartheta}{\bar{a}^2 d \sin^2 \vartheta} \sin \varphi \cos \varphi. \end{aligned} \quad (4.18)$$

Now, (4.11), (4.14), (4.18) yield through (4.2), (3.11), (3.16), (3.9), (4.5)–(4.7) (2.9a,b)

$$\begin{aligned}
 D_{11}^{10} + D_{12}^{10} &= \frac{6}{5(1 + \nu)\mu}, \\
 D_{11}^{10} - D_{12}^{10} &= \frac{3[\alpha^2(3\alpha^2 + 2)(1 + \nu) + 2]}{10\alpha^4(1 + \nu)\mu}, \\
 D_{13}^{10} &= -\frac{3[3\alpha^2 + \nu(\alpha^2 + 4)]}{20(1 + \nu)\mu}, \\
 D_{33}^{10} &= \frac{3[5\alpha^4 + 2\alpha^2 + 4 - \nu\alpha^2(\alpha^2 - 6)]}{20(1 + \nu)\mu}, \\
 D_{44}^{10} &= \frac{3[3\alpha^2 + 4 + \nu(\alpha^2 + 4)]}{20(1 + \nu)\mu}.
 \end{aligned} \tag{4.19}$$

By setting  $\alpha = 1$  (spherical pores) in (4.19), we get through (2.2), (4.5)–(4.7), (2.9a,b) the lower bound (1.2) for  $d\bar{\mu}/dC$  and the exact  $d\bar{\kappa}/dC$  at  $C = 0$  consistently with [1]

### 5 BOUNDS

Insert (3.10) with the help of (2.9a,b) into (2.6). The left-hand side of (2.6) is a non-negative quadratic form of  $E_{ij}^0$ . Condition (2.6), valid for any  $E_{ij}^0 = E_{ji}^0$ , is equivalent to all the principal minors of the matrix of this quadratic form being non-negative, which is the case if and only if

$$\begin{aligned}
 \bar{C}_{11}^0 + \bar{C}_{12}^0 &\leq C_{11}^0 + C_{12}^0, & \bar{C}_{33}^0 &\leq C_{33}^0, \\
 \bar{C}_{11}^0 - \bar{C}_{12}^0 &\leq C_{11}^0 - C_{12}^0, & \bar{C}_{44}^0 &\leq C_{44}^0, \\
 (C_{33}^0 - \bar{C}_{33}^0)(C_{11}^0 + C_{12}^0 - \bar{C}_{11}^0 - \bar{C}_{12}^0) &\geq 2(C_{13}^0 - \bar{C}_{13}^0)^2.
 \end{aligned} \tag{5.1a}$$

In the same way, inserting (2.14), (4.5) into (2.7), we get

$$\bar{D}_{11}^0 + \bar{D}_{12}^0 \leq D_{11}^0 + D_{12}^0, \quad \text{etc.}^\dagger \tag{5.1b}$$

By using (2.12), (2.13), (5.1a,b), the following bounds for  $\bar{C}_{11}^0 + \bar{C}_{12}^0$ ,  $\bar{C}_{11}^0 - \bar{C}_{12}^0$ ,  $\bar{C}_{33}^0$ ,  $\bar{C}_{44}^0$ ,  $\bar{C}_{13}^0$  are obtained:

$$\begin{aligned}
 \frac{1}{D_{11}^0 + D_{12}^0} + \frac{2\bar{C}_{13}^{02}}{\bar{C}_{33}^0} &\leq \bar{C}_{11}^0 + \bar{C}_{12}^0 \leq C_{11}^0 + C_{12}^0, \\
 \frac{1}{D_{11}^0 - D_{12}^0} &\leq \bar{C}_{11}^0 - \bar{C}_{12}^0 \leq C_{11}^0 - C_{12}^0, \\
 \frac{1}{4D_{44}^0} &\leq \bar{C}_{44}^0 \leq C_{44}^0,
 \end{aligned} \tag{5.2a}$$

$$\begin{aligned}
 \frac{1}{D_{33}^0} + \frac{2\bar{C}_{13}^{02}}{C_{11}^0 + C_{12}^0} &\leq \bar{C}_{33}^0 \leq C_{33}^0, \\
 |\bar{C}_{13}^0 - C_{13}^0| &\leq [\frac{1}{2}(\bar{C}_{33}^0 - C_{33}^0)(\bar{C}_{11}^0 + \bar{C}_{12}^0 - C_{11}^0 - C_{12}^0)]^{1/2};
 \end{aligned}$$

and the analogical bounds for  $\bar{D}_{11}^0 + \bar{D}_{12}^0$ ,  $\bar{D}_{11}^0 - \bar{D}_{12}^0$ ,  $\bar{D}_{33}^0$ ,  $\bar{D}_{44}^0$ ,  $\bar{D}_{13}^0$  are

$$\frac{1}{C_{11}^0 + C_{12}^0} + \frac{2\bar{D}_{13}^{02}}{\bar{D}_{33}^0} \leq \bar{D}_{11}^0 + \bar{D}_{12}^0 \leq D_{11}^0 + D_{12}^0, \quad \text{etc.}^\dagger \tag{5.2b}$$

<sup>†</sup> (5.1b), (5.2b) and (5.5b) are obtained from (5.1a), (5.2a) and (5.5a), respectively, replacing formally  $C$  by  $D$  and  $D$  by  $C$ .

In deducing (5.2a), we did not use (5.1b)<sub>5</sub>† and in deducing (5.2b), we did not use (5.1a)<sub>5</sub>. Therefore, if a  $\bar{\mathcal{C}}^0$  meets (5.2a), then  $\bar{\mathcal{D}}^0$  obtained from this  $\bar{\mathcal{C}}^0$  through (2.12) meets (5.2b)<sub>1,2,3,4</sub>† but need not meet (5.2b)<sub>5</sub>†. Define

$$\bar{\mathcal{C}}^{10} = \{\bar{C}_{11}^{10}, \bar{C}_{12}^{10}, \bar{C}_{13}^{10}, \bar{C}_{33}^{10}, \bar{C}_{44}^{10}\} = \left. \frac{d\bar{\mathcal{C}}^0}{dC} \right|_{C=0},$$

i.e.

$$\bar{C}_{11}^{10} = \left. \frac{d\bar{C}_{11}^0}{dC} \right|_{C=0}, \quad \bar{C}_{12}^{10} = \left. \frac{d\bar{C}_{12}^0}{dC} \right|_{C=0}, \quad \text{etc.}$$

and

$$\bar{\mathcal{D}}^{10} = \{\bar{D}_{11}^{10}, \bar{D}_{12}^{10}, \bar{D}_{13}^{10}, \bar{D}_{33}^{10}, \bar{D}_{44}^{10}\} = \lim_{C \rightarrow 0} C\bar{\mathcal{D}}^0.$$

Then

$$\bar{\mathcal{C}}^0 = \bar{\mathcal{C}}^{10}C + O(C^2), \quad (5.3)$$

$$C\bar{\mathcal{D}}^0 = \bar{\mathcal{D}}^{10} + O(C). \quad (5.4)$$

Substituting (3.17), (5.3) into (5.2a) and dividing by  $C$ , we get for  $C \rightarrow 0$  the bounds for  $\bar{C}_{11}^{10} + \bar{C}_{12}^{10}$ ,  $\bar{C}_{11}^{10} - \bar{C}_{12}^{10}$ ,  $\bar{C}_{33}^{10}$ ,  $\bar{C}_{44}^{10}$ ,  $\bar{C}_{13}^{10}$ :

$$\begin{aligned} \frac{1}{D_{11}^{10} + D_{12}^{10}} + \frac{2\bar{C}_{13}^{102}}{\bar{C}_{33}^{10}} &\leq \bar{C}_{11}^{10} + \bar{C}_{12}^{10} \leq C_{11}^{10} + C_{12}^{10}, \\ \frac{1}{D_{11}^{10} - D_{12}^{10}} &\leq \bar{C}_{11}^{10} - \bar{C}_{12}^{10} \leq C_{11}^{10} - C_{12}^{10}, \\ \frac{1}{4D_{44}^{10}} &\leq \bar{C}_{44}^{10} \leq C_{44}^{10}, \\ \frac{1}{D_{33}^{10}} + \frac{2\bar{C}_{13}^{102}}{\bar{C}_{11}^{10} + \bar{C}_{12}^{10}} &\leq \bar{C}_{33}^{10} \leq C_{33}^{10}, \\ |\bar{C}_{13}^{10} - C_{13}^{10}| &\leq [\frac{1}{2}(\bar{C}_{33}^{10} - C_{33}^{10})(\bar{C}_{11}^{10} + \bar{C}_{12}^{10} - C_{11}^{10} - C_{12}^{10})]^{1/2}. \end{aligned} \quad (5.5a)$$

Introducing (4.6), (5.4) into (5.2b), we similarly get the bounds for  $\bar{D}_{11}^{10} + \bar{D}_{12}^{10}$ ,  $\bar{D}_{11}^{10} - \bar{D}_{12}^{10}$ ,  $\bar{D}_{33}^{10}$ ,  $\bar{D}_{44}^{10}$ ,  $\bar{D}_{13}^{10}$ :

$$\frac{1}{C_{11}^{10} + C_{12}^{10}} + \frac{2\bar{D}_{13}^{102}}{D_{33}^{10}} \leq \bar{D}_{11}^{10} + \bar{D}_{12}^{10} \leq D_{11}^{10} + D_{12}^{10}, \quad \text{etc.} \quad (5.5b)$$

Again, if a  $\bar{\mathcal{C}}^{10}$  meets (5.5a), then  $\bar{\mathcal{D}}^{10}$  obtained from this  $\bar{\mathcal{C}}^{10}$  through (2.12), (5.3), (5.4) meets (5.5b)<sub>1,2,3,4</sub>† but need not meet (5.5b)<sub>5</sub>†. Thus, (2.6), (2.7) give the following restrictions on  $\bar{\mathcal{C}}^{10}$ :  $\bar{\mathcal{C}}^{10}$  meets (5.5a) and  $\bar{\mathcal{D}}^{10}$  obtained from this  $\bar{\mathcal{C}}^{10}$  through (2.12), (5.3), (5.4) meets (5.5b)<sub>5</sub>. The restrictions on  $\bar{\mathcal{D}}^{10}$  are analogical.

We see in (5.5a) that the bounds for  $\bar{C}_{13}^{10}$  and the lower bounds for  $\bar{C}_{11}^{10} + \bar{C}_{12}^{10}$  and  $\bar{C}_{33}^{10}$  depend on some other  $\bar{C}_{11}^{10}$ . A similar assertion is valid for the compliances. Consider a three-dimensional space  $(\bar{C}_{11}^{10} + \bar{C}_{12}^{10}) \times \bar{C}_{33}^{10} \times \bar{C}_{13}^{10}$ . Let  $R_C$  denote a set of all points  $\{\bar{C}_{11}^{10} + \bar{C}_{12}^{10}, \bar{C}_{33}^{10}, \bar{C}_{13}^{10}\}$  satisfying (5.5a)<sub>1,4,5</sub>. The cross-section of  $R_C$  by the plane  $\bar{C}_{11}^{10} + \bar{C}_{12}^{10} = C' = \text{const.}$ ,  $C' \in (1/(D_{11}^{10} + D_{12}^{10}), C_{11}^{10} + C_{12}^{10})$ , is generally bounded by three

† (5.1b), (5.2b) and (5.5b) are obtained from (5.1a), (5.2a) and (5.5a), respectively, replacing formally  $C$  by  $D$  and  $D$  by  $C$ .

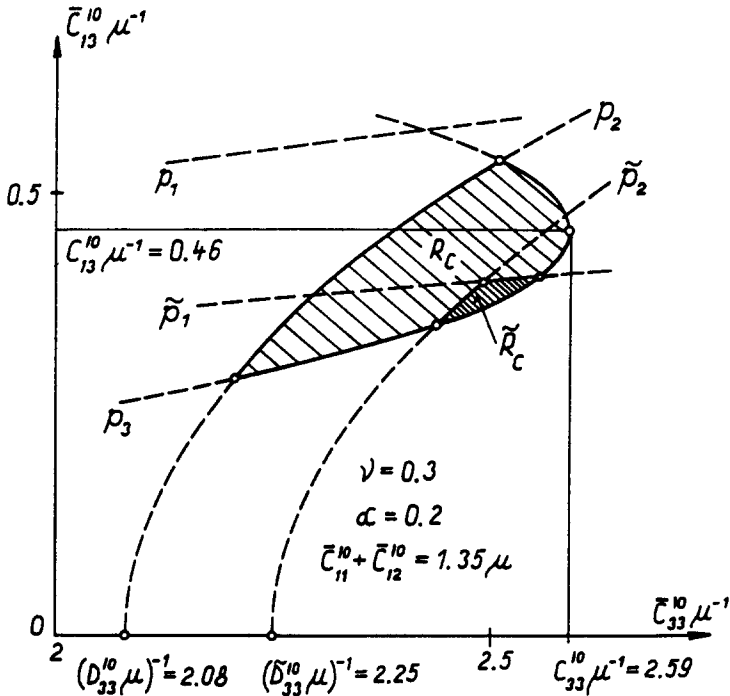

Fig. 3. Cross-section of  $R_C$  and  $\tilde{R}_C$  by the plane  $\bar{C}_{11}^{10} + \bar{C}_{12}^{10} = 1.35 \mu$  for  $\nu = 0.3, \alpha = 0.2$

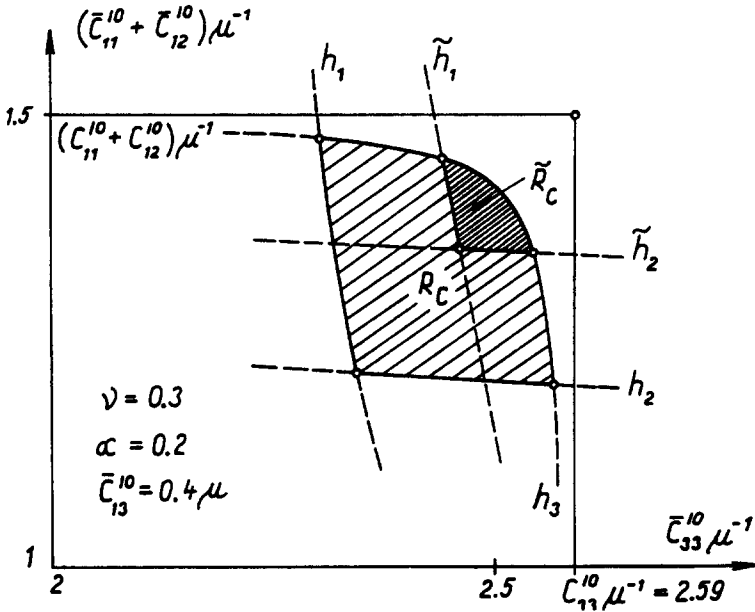

Fig. 4. Cross-section of  $R_C$  and  $\tilde{R}_C$  by the plane  $\bar{C}_{13}^{10} = 0.4 \mu$  for  $\nu = 0.3, \alpha = 0.2$

parabolas  $p_1, p_2, p_3$  with the axes parallel to the  $\bar{C}_{33}^{10}$ -axis. In Fig. 3 this cross-section (bounded by  $p_2, p_3$  only) is shown for  $\nu = 0.3, \alpha = 0.2, \bar{C}_{11}^{10} + \bar{C}_{12}^{10} = 1.35 \mu$ . Similar are the cross-sections of  $R_C$  by the planes  $\bar{C}_{33}^{10} = \text{const.}$ , while those by the planes  $C_{13}^{10} = \text{const.}$  are generally bounded by three hyperbolas  $h_1, h_2, h_3$  with their asymptotes parallel to the  $\bar{C}_{33}^{10}$ - and  $(\bar{C}_{11}^{10} + \bar{C}_{12}^{10})$ -axes. Figure 4 shows this for  $\nu = 0.3, \alpha = 0.2$  and  $\bar{C}_{13}^{10} = 0.4 \mu$ .

## 6. INHOMOGENEOUS STRESS BOUNDARY CONDITIONS FOR HOLLOW ELEMENTS

In the preceding sections the boundary conditions (2.1) or (2.2) were considered on the boundary  $S$  of a body  $V$ .  $E_{ij}^0$ ,  $S_{ij}^0$  were constant tensors. Admissible fields were constructed in  $V$  with the displacement and the stress vector on the surfaces  $\bar{B}$  of all  $\mathcal{E}$  also given by (2.1) and (2.2), respectively. In this section we relax condition (2.2) on  $\bar{B}$  and find a more general admissible stress field. Only the case axially symmetric to  $x_3^0$  axis is considered here. Let  $V$  and  $V' \subset V$  be two aligned spheroids of the same  $\alpha$ , both centered at  $x_i^0 = 0$  with their axes of revolution lying in the  $x_3^0$ -axis. Let  $S$  and  $S'$  be the boundary of  $V$  and  $V'$ , respectively. By  $\Delta V$  we denote the part of  $V$  for which  $S$  is the outer and  $S'$  the inner boundary. Introduce in  $V$  the global spheroidal coordinates  $R, \Theta, \Phi$ , which are in the same relation to  $x_i^0$  as  $r, \vartheta, \varphi$  to  $\bar{x}_i^0$  in  $\mathcal{E}$ . For  $S$  it is  $R = 1 + D$  and for  $S'$ ,  $R = 1$ . Let  $D \ll 1$ . As in Section 2 fill out both  $V'$  and  $\Delta V$  with aligned hollow spheroidal elements  $\mathcal{E}$  of the same  $\alpha$  oriented parallel to  $V$ .

Let the stress vector  $t_i^0$  acting on  $S$  be given by (2.2), where the nonzero components of  $S_{ij}^0$  are

$$S_{11}^0 = S_{22}^0 = \bar{\sigma}_{11}^0 = \bar{\sigma}_{22}^0 = \text{const.}, \quad S_{33}^0 = \bar{\sigma}_{33}^0 = \text{const.} \quad (6.1)$$

$t_i^0$  acting on  $\bar{B}$  of all  $\mathcal{E}$  inside  $V'$  is chosen in the form

$$\begin{aligned} t_i^0 &= \bar{S}_{ij}^0 n_j^0, \\ \bar{S}_{11}^0 &= Y'' \sin^2 \varphi \sin^2 \vartheta + Y' \cos^2 \vartheta + Y, \\ \bar{S}_{22}^0 &= Y'' \cos^2 \varphi \sin^2 \vartheta + Y' \cos^2 \vartheta + Y, \\ \bar{S}_{33}^0 &= X' \sin^2 \vartheta + X, \quad \bar{S}_{12}^0 = -Y'' \sin \varphi \cos \varphi \sin^2 \vartheta, \\ \bar{S}_{13}^0 &= V \cos \varphi \sin \vartheta \cos \vartheta, \quad \bar{S}_{23}^0 = V \sin \varphi \sin \vartheta \cos \vartheta. \end{aligned} \quad (6.2)$$

$Y, Y', Y'', X, X', V$  are constants to be determined later.  $\bar{S}_{ij}^0$  in (6.2) depend in a simple way on  $\vartheta, \varphi$  and meet the conditions of symmetry with respect to the coordinate planes  $\bar{x}_i^0 \bar{x}_j^0$  and to the  $\bar{x}_3^0$ -axis. In fact, using (4.1), we have on  $\bar{B}$

$$\begin{aligned} \bar{a}^2 \sigma^{11} &= (U_1 + \alpha^2 U_2) \sin^2 \vartheta \cos^2 \vartheta + Y \sin^2 \vartheta + \alpha^2 X \cos^2 \vartheta, \\ (1 + d) \bar{a}^2 \sigma^{12} &= [(U_1 + \alpha^2 U_2) \cos^2 \vartheta + Y - \alpha^2 X - \alpha^2 U_2] \sin \vartheta \cos \vartheta, \\ \sigma^{13} &= 0, \quad U_1 = Y' + \alpha V, \quad U_2 = X' + (1/\alpha)V. \end{aligned} \quad (6.3)$$

Notice that  $\sigma^{ij}$  do not depend on  $\varphi$ . For any  $\mathcal{E}$  cut off the material the equations of equilibrium (4.9) and (6.3) yield, in the same way as in the case ( $\alpha$ ) in Section 4,  $\sigma^{22}$ ,  $\sigma^{23}$ ,  $\sigma^{33}$  to  $O(d^{-1})$  in the form

$$\begin{aligned} \sigma^{22} &= \frac{1}{2\bar{c}^2 d} (X + \frac{1}{2} U_2 \sin^2 \vartheta), \quad \sigma^{23} = 0, \\ \sigma^{33} &= \frac{1}{2\bar{a}^2 d \sin^2 \vartheta} \left[ 2(U_1 + \alpha^2 U_2) \sin^2 \vartheta \cos^2 \vartheta \right. \\ &\quad \left. + \left( 2Y - 2\alpha^2 X - \frac{\alpha^2}{2} U_2 \right) \sin^2 \vartheta + \alpha^2 X \right]. \end{aligned} \quad (6.4)$$

Any point of  $S'$  is a contact point of  $S'$  with a  $\bar{B}$  of some  $\mathcal{E}$ , and for this point it is  $\vartheta = \Theta, \varphi = \Phi$ . Thus,  $t_i^0$  acting on  $S'$  has the same form as (6.2), only  $\Theta, \Phi$  must be written instead of  $\vartheta, \varphi$ . We see that the surface loads acting on  $S, S'$  or on any  $\bar{B}$  in

$V'$  are in equilibrium.  $\bar{B}$  are not loaded. As  $D \ll 1$ ,  $\Delta V$  is a thin boundary layer close to  $S$ , and the volume integrals of  $\sigma_{ij}^0$ , or  $\sigma_{ij}^0 \epsilon_{ij}^0$ , over  $\Delta V$  are small with respect to those over  $V'$ . Thus, it is

$$\begin{aligned}\bar{\sigma}_{ij}^0 &= \frac{1}{V} \int_V \sigma_{ij}^0 dV \approx \frac{1}{V'} \int_{V'} \sigma_{ij}^0 dV \\ &= \frac{1}{2V'} \int_{\bar{B}} (t_i^0 \bar{x}_j^0 + t_j^0 \bar{x}_i^0) dB.\end{aligned}\quad (6.5)$$

Using (6.2), we calculate from (6.5)

$$\bar{\sigma}_{11}^0 = \bar{\sigma}_{22}^0 = Y + \frac{1}{2}U_1, \quad \bar{\sigma}_{33}^0 = X + \frac{1}{2}U_2, \quad \text{all other } \bar{\sigma}_{ij}^0 = 0. \quad (6.6)$$

By using (6.6),  $\sigma^{22}$ ,  $\sigma^{33}$  in (6.4) can be expressed through  $\bar{\sigma}_{11}^0$ ,  $\bar{\sigma}_{33}^0$ ,  $X$  and  $Y$ , only. Similarly to Section 4,  $W^{(\sigma)}$  to  $O(d^{-1})$  is calculated in the form

$$\begin{aligned}W^{(\sigma)} &= \frac{M - \nu N}{2^3 \cdot 3 \cdot 5 \cdot 7 d (1 + \nu) \mu}, \\ M &= 2^2 [2^2 A^2 + E^2 + 2 \cdot 3 (2AB + EF) + 3 \cdot 7 (B^2 + F^2)] + H, \\ N &= 2^3 [2A(E + 3F) + 3B(E + 7F)] + H, \\ H &= 2 \cdot 3 \cdot 7 \alpha^2 X (2A + 5B + E + 5F) + 3^2 \cdot 5 \cdot 7 \alpha^4 X^2, \\ A &= 5(\bar{\sigma}_{11}^0 - Y) + \frac{1}{2} \alpha^2 (\bar{\sigma}_{33}^0 - X), \quad B = 2(Y - \alpha^2 X) - \frac{1}{2} \alpha^2 (\bar{\sigma}_{33}^0 - X), \\ E &= \frac{1}{2} (\alpha^2 - 1) (\bar{\sigma}_{33}^0 - X), \quad F = (1 - \alpha^2) X + \frac{1}{2} (\bar{\sigma}_{33}^0 - X).\end{aligned}\quad (6.7)$$

For fixed  $\bar{\sigma}_{11}^0 = \bar{\sigma}_{22}^0$ ,  $\bar{\sigma}_{33}^0$  and for any  $X$ ,  $Y$ ,  $W^{(\sigma)}$  given to  $O(d^{-1})$  by (6.7) is the strain energy density of a statically admissible stress field for the boundary-value problem (2.2), (6.1) of the spheroid  $V$ . As in Section 4,  $\alpha$  or  $1/\alpha$  are not close to zero. Setting  $X = \bar{\sigma}_{33}^0$ ,  $Y = \bar{\sigma}_{11}^0 = \bar{\sigma}_{22}^0$ , we get from (6.6)  $U_1 = U_2 = 0$ , and we see that  $\sigma^{ij}$  in (6.3) are the same as  $\sigma^{ij}$  in (4.10) for the case  $(\alpha)$  with (2.2) applied on  $\bar{B}$ .

To obtain the lowest possible  $W^{(\sigma)}$  for fixed  $\bar{\sigma}_{11}^0$ ,  $\bar{\sigma}_{33}^0$ , we determine  $X$ ,  $Y$  from the conditions

$$\frac{\partial W^{(\sigma)}}{\partial X} = 0, \quad \frac{\partial W^{(\sigma)}}{\partial Y} = 0. \quad (6.8)$$

By using (6.7), the conditions (6.8) take on the form

$$\begin{aligned}\{(8 + 14\alpha^2 + 85\alpha^4) + \nu\alpha^2(22 - 7\alpha^2)\}X + 2^3\{11\alpha^2 + \nu(8 + 7\alpha^2)\}Y \\ = 2^3 \cdot 5 \{2^2 \alpha^2 + \nu(1 + 2\alpha^2)\} \bar{\sigma}_{11}^0 + \{5(4 - 2\alpha^2 + 5\alpha^4) + \nu\alpha^2(2 + \alpha^2)\} \bar{\sigma}_{33}^0, \\ \{11\alpha^2 + \nu(8 + 7\alpha^2)\}X + 2^6 Y = 2^3 \cdot 5 \bar{\sigma}_{11}^0 + 5\{7\alpha^2 + \nu(4 - \alpha^2)\} \bar{\sigma}_{33}^0.\end{aligned}\quad (6.9)$$

By solving (6.9) for  $X$ ,  $Y$  and inserting into (6.7),  $W^{(\sigma)}$  to  $O(d^{-1})$  is obtained as a quadratic form in  $\bar{\sigma}_{11}^0$ ,  $\bar{\sigma}_{33}^0$ . In accordance with the notation in Section 4 we write

$$CW^{(\sigma)} = (\bar{D}_{11}^{10} + \bar{D}_{12}^{10}) \bar{\sigma}_{11}^{02} + \frac{1}{2} \bar{D}_{33}^{10} \bar{\sigma}_{33}^{02} + 2 \bar{D}_{13}^{10} \bar{\sigma}_{11}^0 \bar{\sigma}_{33}^0 + O(C). \quad (6.10)$$

$\bar{D}_{11}^{10} + \bar{D}_{12}^{10}$ ,  $\bar{D}_{33}^{10}$ ,  $\bar{D}_{13}^{10}$  are not given here explicitly for any  $\alpha > 0$ . Some results of numerical calculations are shown in Figs 3 and 4.

Let  $\bar{R}_C$  denote a set of all points  $\{\bar{C}_{11}^{10} + \bar{C}_{12}^{10}, \bar{C}_{33}^{10}, \bar{C}_{13}^{10}\}$  satisfying (5.5a)<sub>1,4,5</sub> with  $\bar{D}_{11}^{10} + \bar{D}_{12}^{10}$ ,  $\bar{D}_{33}^{10}$ ,  $\bar{D}_{13}^{10}$  written instead of  $D_{11}^{10} + D_{12}^{10}$ ,  $D_{33}^{10}$ ,  $D_{13}^{10}$ . Figures 3 and 4 show that, for the chosen  $\nu$ ,  $\alpha$ ,  $\bar{R}_C$  is a small part of  $R_C$ . We see that the statically admissible



stress field constructed in this section for the inhomogeneous stress boundary conditions (6.2) with  $X$ ,  $Y$  determined by (6.8) improves the respective bounds considerably.

An interested result is obtained for the simple case  $\alpha = 1$ . In this case the pores are spherical and the material macroscopically isotropic. Setting  $\bar{\sigma}_{11}^0 = \bar{\sigma}_{22}^0 = 0$  we find from (6.9) simply

$$X = -\frac{1+5\nu}{7-5\nu}\bar{\sigma}_{33}^0, \quad Y = \frac{4}{7-5\nu}\bar{\sigma}_{33}^0. \quad (6.11)$$

We substitute (6.11) into (6.7) and get (6.10) in the form

$$CW^{(m)} = \frac{3(1-\nu)(9+5\nu)}{2^3\mu(1+\nu)(7-5\nu)}\bar{\sigma}_{33}^0{}^2 + O(C). \quad (6.12)$$

For this special case  $W$  from (2.9a) is

$$W = \frac{1}{2}\bar{C}_{33}^0\bar{\sigma}_{33}^0{}^2 = (1/2\bar{E})\bar{\sigma}_{33}^0{}^2,$$

where  $\bar{E}$  is the macroscopic Young modulus. Inserting this and (6.12) into (2.7) gives for  $C \rightarrow 0$

$$\left. \frac{d\bar{E}}{dC} \right|_{C=0} \geq \frac{4\mu(1+\nu)(7-5\nu)}{3(1-\nu)(9+5\nu)}. \quad (6.13)$$

It is

$$\bar{\mu} = 3\bar{\kappa}\bar{E}/(9\bar{\kappa} - \bar{E}). \quad (6.14)$$

For the bulk modulus  $\bar{\kappa}$  we find from [1]

$$\left. \frac{d\bar{\kappa}}{dC} \right|_{C=0} = \frac{4(1+\nu)\mu}{9(1-\nu)}. \quad (6.15)$$

(6.13)–(6.15) yield

$$\left. \frac{d\bar{\mu}}{dC} \right|_{C=0} \geq \frac{(7-5\nu)\mu}{15(1-\nu)},$$

which together with (1.2) gives the result

$$\left. \frac{d\bar{\mu}}{dC} \right|_{C=0} = \frac{(7-5\nu)\mu}{15(1-\nu)}.$$

Thus, the statically admissible stress field of this section in the case of  $\alpha = 1$  gives a lower bound for  $d\bar{\mu}/dC|_{C=0}$  that coincides with its upper bound (1.2) obtained from [2]. Therefore, for  $C \ll 1$  and spherical pores it is

$$\bar{\mu} = \frac{(7-5\nu)\mu}{15(1-\nu)}C + O(C^2).$$

## 7. CONCLUDING REMARKS

Equations (3.20)–(3.22) give the coefficients of the form  $W^{(m)}$  of the kinematically admissible displacement to  $O(C)$  for any  $\alpha > 0$ . For  $\alpha \rightarrow 0$  and  $\alpha \rightarrow \infty$  the pores become

infinite cylinders and layers, respectively. By taking the limits  $\alpha \rightarrow 0$ ,  $\alpha \rightarrow \infty$  in (3.20)–(3.22), the same  $W^{(u)}$  to  $O(C)$  is obtained as if we calculate  $W^{(u)}$  to  $O(C)$  directly for infinite hollow cylinders and layers.  $W^{(\sigma)}$  calculated in Sections 4 and 5 using the membrane theory are to  $O(C^{-1})$  for not much prolate or oblate spheroids ( $\alpha$  or  $1/\alpha$  are not close to zero).

The variational principles formulated in Section 2 yield some inequalities or bounds for the derivatives with respect to  $C$  at  $C = 0$  of macroscopic moduli and compliances [see (5.5a,b) in Section 5]. Only for  $\bar{C}_{11}^{10} - \bar{C}_{12}^{10}$  and  $\bar{C}_{44}^{10}$  (or  $\bar{D}_{11}^{10} - \bar{D}_{12}^{10}$  and  $\bar{D}_{44}^{10}$ ) these bounds are constant. The bounds for  $\bar{C}_{11}^{10} + \bar{C}_{12}^{10}$ ,  $\bar{C}_{33}^{10}$ ,  $\bar{C}_{13}^{10}$  (or  $\bar{D}_{11}^{10} + \bar{D}_{12}^{10}$ ,  $\bar{D}_{33}^{10}$ ,  $\bar{D}_{13}^{10}$ ) are coupled, which makes an analysis of these inequalities more difficult (see the end of Section 5).

$W^{(u)}$  to  $O(C)$  and  $W^{(\sigma)}$  to  $O(C^{-1})$  of the admissible fields satisfying homogeneous conditions (2.1) and (2.2), respectively, are relatively simple. This is not the case with  $W^{(\sigma)}$  derived in Section 6 for inhomogeneous conditions (6.2). However, this latter  $W^{(\sigma)}$  coincides for  $\alpha = 1$  to  $O(C^{-1})$  with the exact  $W$  yielding the exact  $d\bar{\mu}/dC$ ,  $d\bar{\kappa}/dC$  at  $C = 0$ . Thus, by taking the limits  $\alpha \rightarrow 1^+$  in (3.20), (3.21) and  $\alpha \rightarrow 1^-$  in (3.20), (3.22), we get the exact  $\bar{C}_{11}^{10}$ ,  $\bar{C}_{12}^{10}$ ,  $\bar{C}_{13}^{10}$ ,  $\bar{C}_{33}^{10}$ ,  $\bar{C}_{44}^{10}$ . Also, as we illustrated numerically in Figs 3, 4, this  $W^{(\sigma)}$  for  $\alpha \neq 1$  considerably narrows the region  $R_C$ , where  $\bar{C}_{11}^{10} + \bar{C}_{12}^{10}$ ,  $\bar{C}_{33}^{10}$ ,  $\bar{C}_{13}^{10}$  must occur. We conclude that for  $C \ll 1$  the macroscopic moduli  $\bar{C}_{11}^0$ ,  $\bar{C}_{12}^0$ ,  $\bar{C}_{13}^0$ ,  $\bar{C}_{33}^0$ ,  $\bar{C}_{44}^0$  can be approximated in a certain neighbourhood of  $\alpha = 1$  by

$$\bar{C}_{11}^0 = C_{11}^{10}C, \quad \bar{C}_{12}^0 = C_{12}^{10}C, \quad \bar{C}_{13}^0 = C_{13}^{10}C, \quad \bar{C}_{33}^0 = C_{33}^{10}C, \quad \bar{C}_{44}^0 = C_{44}^{10}C, \quad (7.1)$$

where  $C_{11}^{10}$ ,  $C_{12}^{10}$ , etc. are given by (3.20)–(3.22).

On the basis of the correspondence principle, (7.1) can be used to define approximate complex macroscopic moduli if the matrix is viscoelastic.

#### REFERENCES

1. Z. Hashin, *J. Appl. Mech.* **29**, 143 (1962).
2. Z. Hashin, In *Mechanics of Composite Materials*, Proc 5th Symp Naval Struct Mech. (Edited by F. W. Wendt, H. Liebowitz and N. Perrone), pp. 201–242. Pergamon Press, New York (1967)
3. V. V. Novozhilov, *Theory of Thin Shells*. Noordhoff (1959)